

SECTION IB - IB
STYLE 2

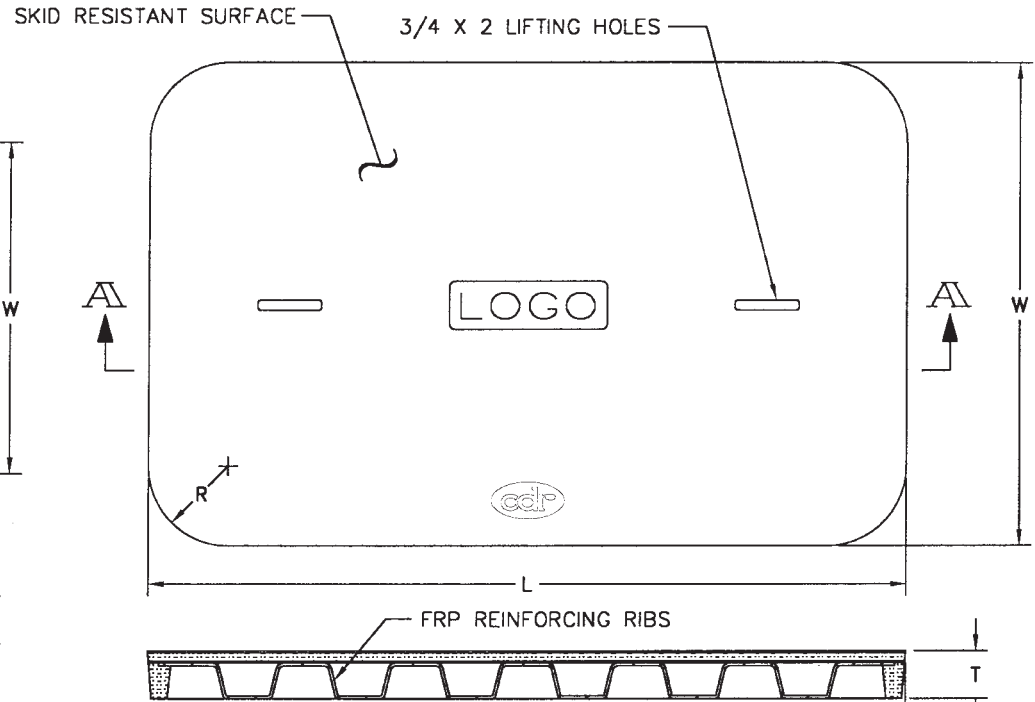

SECTION A - A
STYLE 1

STYLE 2						
SIZE	L	W	T	R	C	COMMENTS
R-1017-2C	15-3/8	10-1/8	1-3/4	1	1/8	FITS BROOKS #36 AND CHRISTY #B-9
R-1220-2C	18-1/8	11-1/4	1-3/4	1	1/8	FITS BROOKS #37 AND CHRISTY #B-12
R-1324-2	23-1/4	13-3/4	2	1-3/8	1/8	FITS BROOKS #38
R-1517-2C	14 9/16	16 9/16	1-1/2	2 1/2	1/8	FITS BROOKS DUAL H-METER BOX
R-1527-2C	26 7/8	15 1/4	1 3/4	1 3/8	1/8	FITS BROOKS #65
R-1730-2	30-1/2	17-1/2	2	1-3/8	1/8	FITS BROOKS #66
R-2042-2	43-1/8	21-1/8	2	1-3/8	3/16	FITS CHRISTY #B-44
R-2436-3	35-5/8	24	3	5	3/16	FITS BROOKS #67

STYLE 1					
CAT. No.	L	W	T	R	C
R-3048-3	47-5/8	30-1/8	3	5	1/4
R-3060-3	59-5/8	30	3	5	1/4

- CDR'S COVERS ARE AVAILABLE FOR LIGHT TRAFFIC OR HEAVY DUTY LOADING
- OPTIONS: INDIVIDUAL LOGOS, BOLTED AND NON-BOLTED, SELF CLOSING METER READING DOOR.

cdr CDR SYSTEMS GROUP
146 SOUTH ATLANTIC AVE., ORMOND BEACH, FL. 32176

TITLE REPLACEMENT COVERS			
DRAWN	E. HODGKINS	DATE	7/1/02
CHECKED		A size	131-0001
APPROVED	AOK		