



**CDR
SYSTEMS
GROUP**

146 SOUTH ATLANTIC AVENUE • ORMOND BEACH, FL 32176
TEL: 386-615-9510 • FAX: 386-615-9606 • E-MAIL: sales@cdrsystems.com

CATALOG INDEX

Service Boxes & Vaults
QAV II – Quick Assembly Vaults
Convertible Pedestal/Handhole
Load Specification Sheet

Small Boxes	Page	Large Boxes	Page
06 x 08 Series	A-05	30 X 48W Series (Flared Wall)	B-50
10 x 15 Series	A-10	30 X 48W Series (Straight Wall)	B-51
11 x 18 Series	A-20	30 X 48 Series	C-10
11 x 21 Series	A-22	30 X 60 Series	C-30
11 x 32 Series	A-25	30 X 60W Series	C-31
12 x 12 Series	A-30	36 X 36 Series	C-34
13 x 24 Series (Flared Wall)	B-10	36 X 60 Series	C-40
13 x 24 Series (Straight Wall)	B-11	36 x 60W Series	C-40A
15 x 17 Series	B-12	36 X 72 Series	C-41
15 x 27 Series	B-13	36 X 72W Series	C-41A
16 x 22 Series	B-16	36 X 96 Series	C-41B
17 x 30 Series (Flared Wall)	B-20	48 X 48 Series	C-42
17 x 30 Series (Straight Wall)	B-21	48 X 48 Round Series	C-42A
24 x 24 Series	B-28	48 X 72 Series	C-43
24 x 36 Series (Flared Wall)	B-30	48 X 78 Series	C-50
24 x 36 Series (Straight Wall)	B-31	48 X 96 Series	C-60
24 X 60 Series	B-40		

Special Purpose	Page	Product Details	Page
Replacement Covers	D-10	Reader Lids and Mouseholes	D-30
Trench Covers	D-20	Typical Wall Sections	D-50
Round Box (2700 Series)	D-21	Large Box Details & Options	D-60
Round Box (3200 Series)	D-21A	Adjust-to-Grade	D-70
Round Box (3900 Series)	D-21B		
Street Rated Boxes	D-22		
Torsion Assist Boxes	D-25		

Surface Equipment Supports	Page
Equipment-Transformer Pads	E-10
Boxpads	E-20



• LIGHTEST • STRONGEST •

SERVICE BOXES • VAULTS • TRANSFORMER PADS • EQUIPMENT PADS

12/28/04



"BUILD-A-PART" NUMBERING SYSTEM

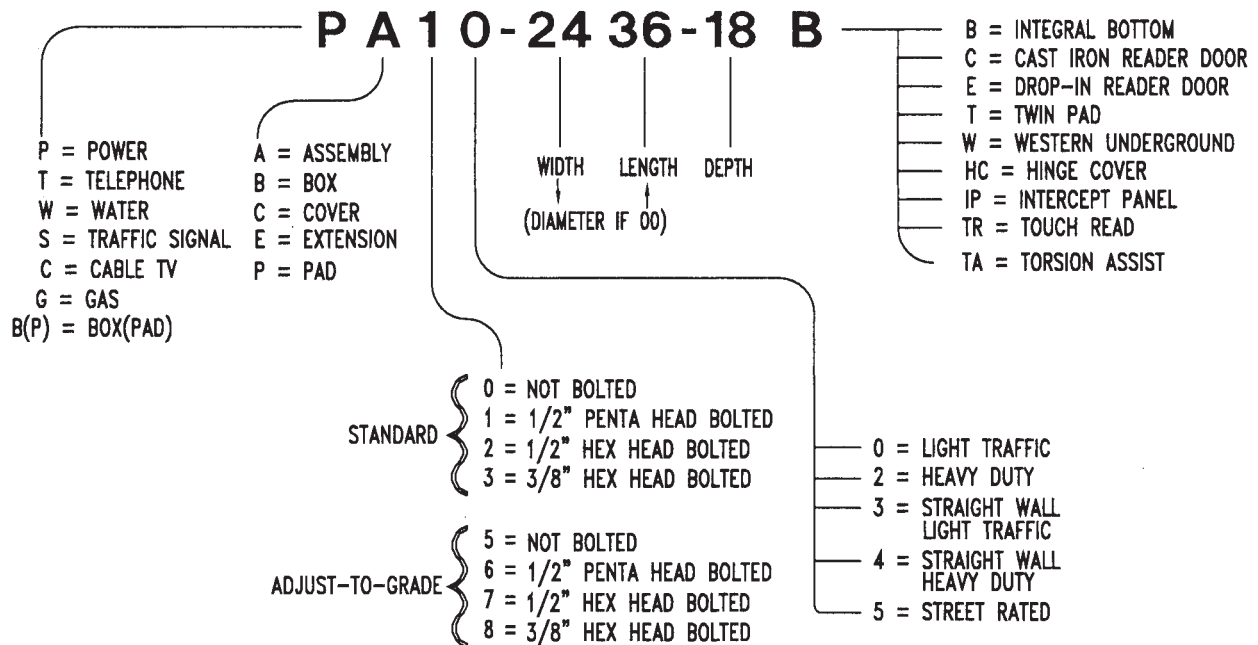

5/9/06

CDR is VERSATILE; we build our products with the features you order. The diagram above explains how our catalog numbering system allows you to design your own box assembly from the many options available.

LIGHT TRAFFIC boxes are rated for use in sidewalks, paved pedestrian areas or areas not subject to heavy vehicular traffic.

HEAVY DUTY boxes are rated for uses in alleys, driveways, parking lots, or areas subject to heavy vehicles.

STREET RATED boxes are suitable for use in streets subject to AASHTO H-20 loads and are available in certain sizes.

Boxes with different depths, special features or in different sizes are available and can be made to order. Boxes can be ordered with integral or separate bottoms. To insure strength and rigidity, boxes over 30" deep should have a bottom.

Covers are available with or without bolting capability, 1/2" stainless steel penta head hardware is standard. Other hardware should be specified.

Covers are available with standard or specified logos. "Electric" is standard on Power boxes; "Telephone" is standard on Telephone boxes, etc.